

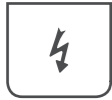

# Rizer



## SELF-PROPELLED SCISSOR LIFTS (ELECTRIC DRIVE)

### STANDARD FEATURES

- + **Folding Handrails:**  
Convenient for storage, transportation and traction through standard doors and elevators
- + **Extended Platform**
- + **Turning Radius: 0**
- + **Automatic Pothole Protection:**  
Superior traction and safety in an elevated position
- + **Intelligent Control on ECU**

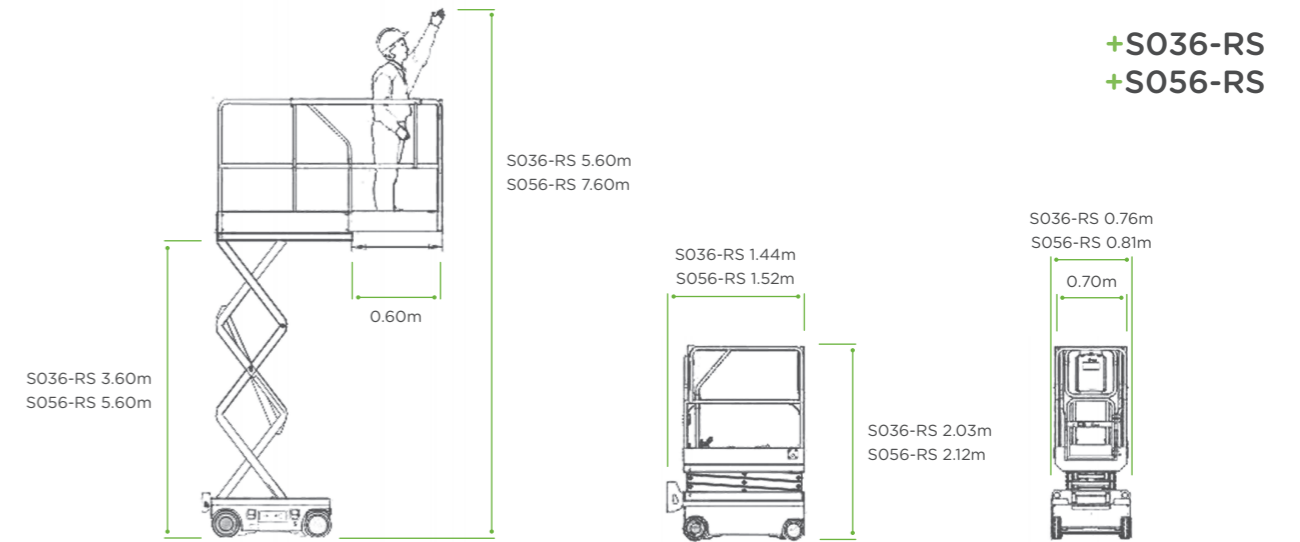

+S036-RS  
+S056-RS

	S036-RS	S056-RS
S.W.L	240kg	230kg
S.W.L ON EXTENSION	100kg	113kg
MAX. OCCUPANTS - INDOOR	2	2
MAX. OCCUPANTS - OUTDOOR	1	0
WORKING HEIGHT	5.60m	7.60m
PLATFORM FLOOR HEIGHT	3.60m	5.60m
OVERALL LENGTH - WITH LADDER	1.44m	1.52m
OVERALL LENGTH - WITHOUT LADDER	1.29m	1.37m
OVERALL WIDTH	0.76m	0.81m
OVERALL HEIGHT - RAILS UP	2.03m	2.12m
OVERALL HEIGHT - RAILS DOWN	1.67m	1.76m
PLATFORM SIZE	1.29x0.70m	1.37x0.70m
PLATFORM EXTENSION SIZE	0.60m	0.60m
GROUND CLEARANCE - STOWED	0.06m	0.06m
GROUND CLEARANCE - RAISED	0.015m	0.015m
WHEELBASE	1.05m	1.13m
TURNING RADIUS - INSIDE	0.40m	0.45m
TURNING RADIUS - OUTSIDE	1.55m	1.60m
GRADEABILITY	25%	25%
MAXIMUM WORKING SLOPE	1.5°/3°	1.5°/3°
STOWED SPEED	4.2km/h	4.0km/h
RAISED SPEED	1.1km/h	0.6km/h
UP/DOWN SPEED	34/28sec	26/21sec
WIND RATED SPEED	12.5m/s	N/A
DRIVE MOTORS	2x24VDC/0.4kW	2x24VDC/0.5kW
LIFTING MOTOR	24VDC/0.8kW	24VDC/2.2kW
BATTERIES	2x12V/85Ah	2x12V/115Ah
INTEGRATED CHARGER	24V/10A	24V/10A
TYRES	Ø230x80mm	Ø230x100mm
WEIGHT	880kg	1240kg

